

**THREE PHASE**

**STORAGE INVERTER**

**QUICK INSTALLATION GUIDE**

**ISSUE: V1.3**

**DATE: 2025-11-24**

**FOXESS CO., LTD.**



## Notice

1. The information in this document may not be modified, copied or reproduced, in whole or in part, without the prior written permission of FOXESS CO., LTD. All information in this document is provided to the best of our knowledge and efforts, but does not constitute a warranty of any kind, express or implied. You can download quick guide and user manual by scanning the QR code.



2. Only certified electricians are allowed to operate the device. Operation personnel must wear proper personal protective equipment (PPE).

3. Before installing the device, check that the package contents are intact and complete against the packing list. If any damage is found or any component is missing, contact your dealer.

4. The device damage caused by the violation of instructions in this document is not covered under warranty.

5. The cable colors involved in this document are for reference only. Select cables in accordance with local cable specifications.

## 1 Packing List

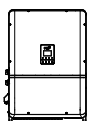

A

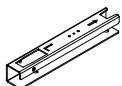

B

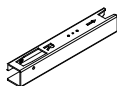

C



D



E

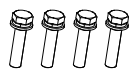

F



G



H



I



J

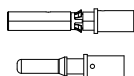

K



L

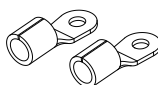

M

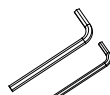

N



O

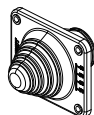

P



Q



R



S

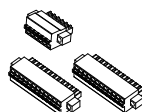

T

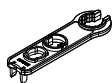

U



V

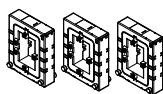

W



X

OBJ	QTY	DESC	OBJ	QTY	DESC
A	1	Inverter	B	1	Left Hanging Plate
C	1	Right Hanging Plate	D	1	Hanging Plate Connection Bar
E	4	Screw-in Type Handle	F	4	M10 × 45 Bolt Assembly
G	4	M10 Hexagon Nut	H	4	M4 × 10 Screw
I	2	M6 × 65 Bolt Assembly	J	8/16	DC Connector (Positive × 4/8, Negative × 4/8)
K	8/16	DC Pin Plug (Positive × 4/8, Negative × 4/8)	L	12	M5 × 16 Bolt Assembly
M	2	Ground Terminal	N	2	5 mm & 10 mm Internal Hexagon Wrench
O	1	Quick Installation Guide	P	3	Cable Gland Plate
Q	1	Load Connection Box	R	1	Grid Connection Box
S	1	Generator Connection Box	T	3	12 P Communication Connector × 2, 6 P Communication Connector × 1
U	1	DC Connector Removal Tool	V	1	Meter
W	3	CT	X	1	Antenna

## 2 Required Tools

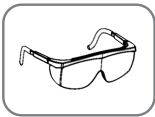

Safety Goggles



Steel Toe Boots

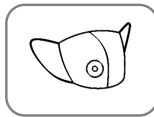

Dust Mask



Helmet



Insulating Gloves

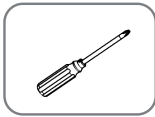

Phillips-Head Screwdriver

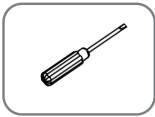

Flat-Head Screwdriver

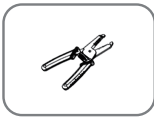

Wire Stripper



Electric Drill



Adjustable Wrench

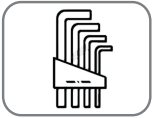

Hex Wrench Set

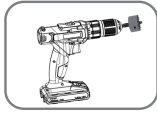

Hole Punch

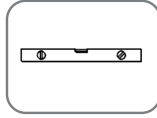

Level



Tape



Sleeve



Multimeter



Phone



**DANGER:**

**Special care must be taken to protect personal safety.**  
PPE must be worn during transfer and installation.



**WARNING:**

Please use proper protective measures, such as foam or protective cloth, keep the equipment well protected from hard objects that may damage their exterior appearance or body during handling and installation.

**3 Inverter Installation**

**3.1 Installation Environment**

Please make sure the inverter will be installed with a proper distance as shown below.

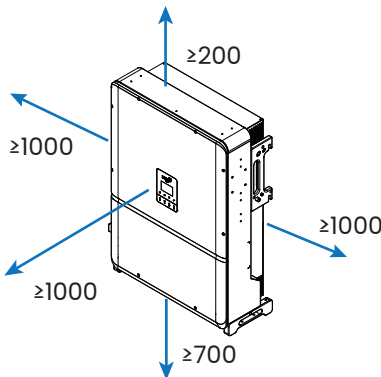

Position	Min Size
Left	1000 mm
Right	1000 mm
Top	200 mm
Bottom	700 mm
Front	1000 mm

### 3.2 Installation Steps

#### Step 1: Hanging Plate Assembly

Install the Inverter on a bracket or wall by means of the hanging plate. The hanging plate assembly diagram and the size of the assembled hanging plate are shown as below:

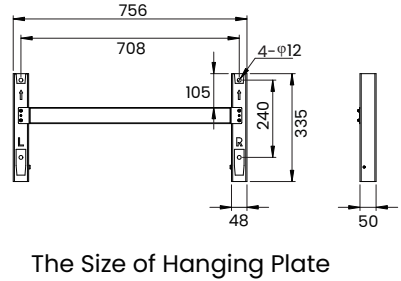
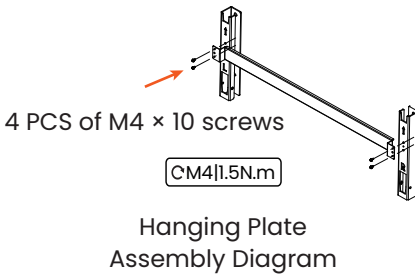

#### Step 2: Bracket-mounted or Wall-mounted Installation

##### Method 1: Bracket-mounted Installation

1. Place the assembled hanging plate on a PV bracket, adjust the angle with a level, mark drilling positions, and drill holes with an electric drill (with a φ12 drill bit).

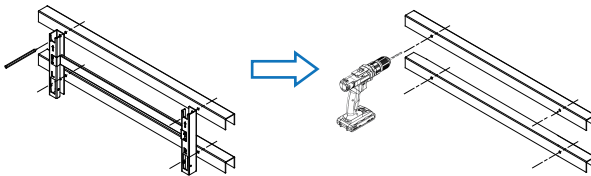

2. Fix the hanging plate with bolts.

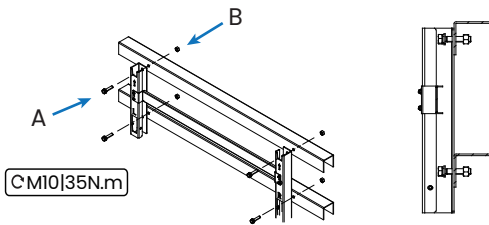

A: 4 PCS of M10 × 45 hexagon bolts  
B: 4 PCS of hexagon nuts

## Method 2: Wall-mounted Installation

1. Place the assembled hanging plate at the installation site, adjust the angle with a level, and mark drilling positions.

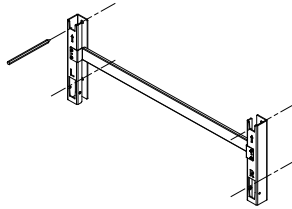

2. Drill holes with a hammer drill (with a  $\phi 12$  drill bit), clear holes, insert 4 PCS of expansion bolts (by client, M10  $\times$  95 is recommended) into holes, and fix them with a rubber hammer.

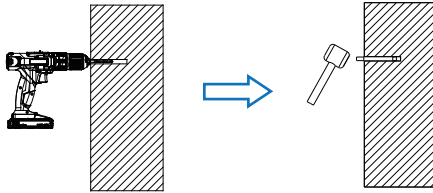

3. Fix the hanging plate with expansion bolts.

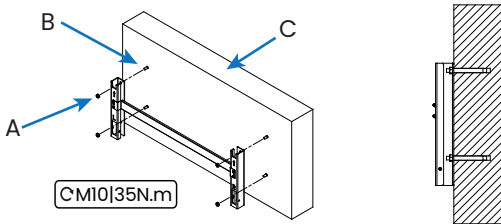

- A: 4 PCS of M10 hexagon nuts
- B: 4 PCS of expansion bolts (M10)
- C: Wall

### Step 3: Inverter Installation

1. Lift the inverter from the package box with 4 PCS of screw-in type handles.

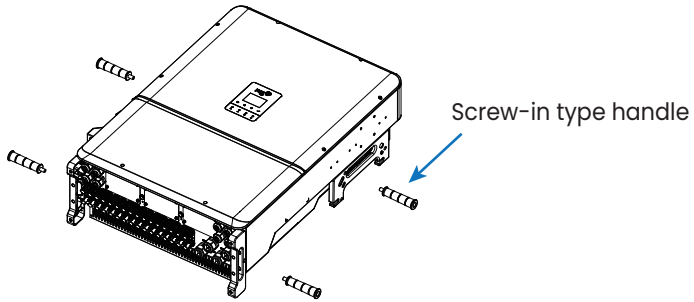

2. Install the inverter on the hanging plate, and ensure that lugs of the inverter are properly matched with slots of the hanging plate.

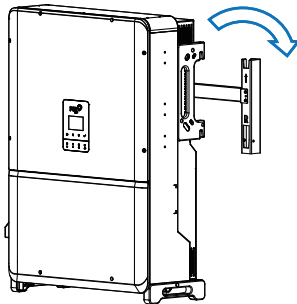

3. Secure the inverter with bolts.

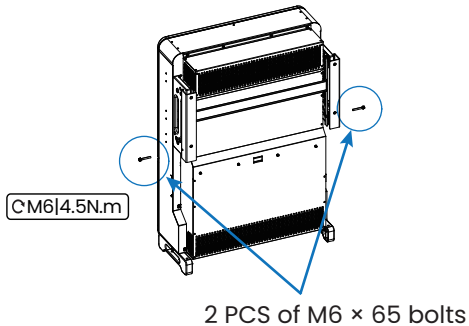

### Step 1: Secondary Ground Connection

Lock crimped ground cables to ground holes with screw locks on the inverter case, and paint the ground screws and ground terminals to improve anti-corrosion characteristics.

The conductor sectional area of each ground cable is 25–50 mm<sup>2</sup> (30–35 mm<sup>2</sup> is recommended).

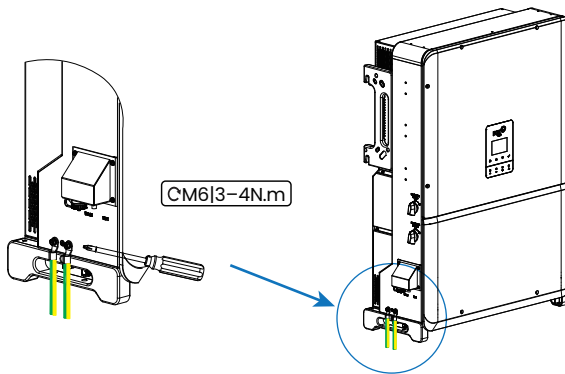

### Step 2: DC Side Connection

1. Turn off the DC switch.
2. It is recommended that the DC cable dedicated to photovoltaics (4–6 mm<sup>2</sup>) be used to connect the PV module.
3. Trim about 6 mm of insulation from the cable end.



4. Separate the DC connector as below.

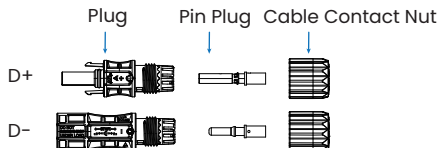

### NOTICE

To ensure the reliability of the DC cable connection and the stable operation of the machine, it is essential to use the matching DC connector.

5. Insert multiple cables connected to the PV module into the pin plug and ensure all strands are captured in the pin plug.
6. Crimp the pin plug with a crimping plier.

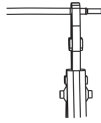

7. Route the crimped cable through the nut into the plug. When you hear a “click”, the pin plug is properly clamped in the plug.

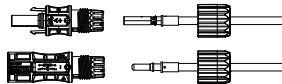

### Step 3: AC Side Connection

Recommended Specification:

Cable Type	Outer Diameter (mm)	Copper Conductor Sectional Area (mm <sup>2</sup> )
LOAD/GRID/GEN Cable	40–70	L1,L2,L3,(N) cables: 90–150 PE: S/2 (S is a sectional area of LOAD/GRID/GEN phase cable)



#### NOTICE

Do not strip or cut cable wires inside or near the lower enclosure. Before routing multi-core cable wires into the lower enclosure, check and remove any broken or damaged cable strands at the cable ends. Loose strands may fall into the enclosure and cause a short circuit.

1. Open the lower enclosure with a 5 mm internal hexagon wrench. Open the breaker and prevent accidental reclosing. Use a Phillips screwdriver to remove the bottom cover for wiring, and keep the removed screws for subsequent installation of the connection box.

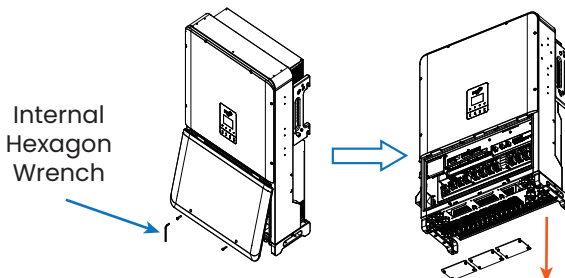

2. Pass the independent grounding wire through the cable gland COM8, insert it into the grounding connector, and tighten it with a 5 mm internal hexagon wrench.

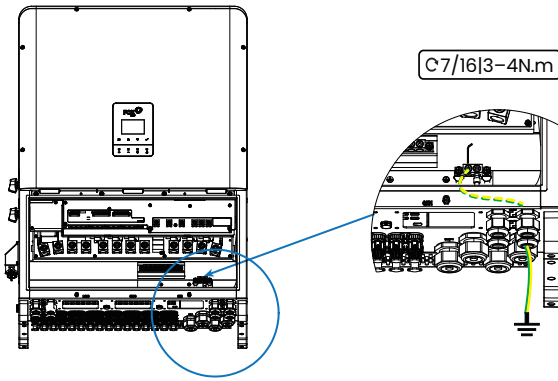

3. Fix the cable gland plate and connection box with M5 × 16 screws. Strip the cable insulation layer, then cut the cable gland plate passthrough hole according to the cable size and pass the cable through the cable gland plate.

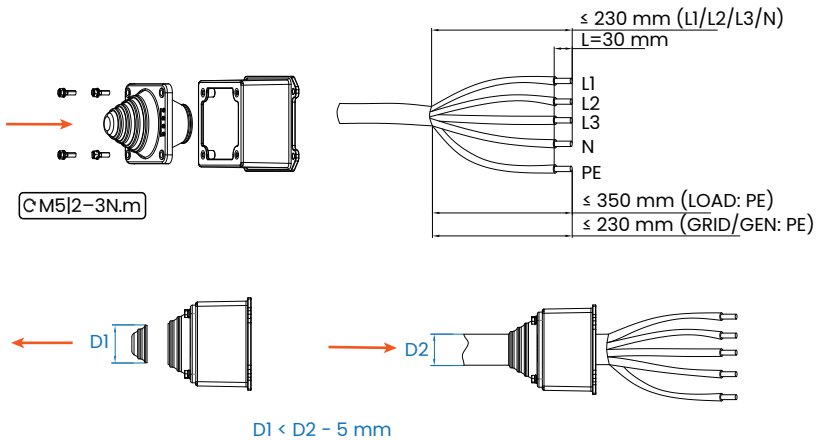

4. Pass the LOAD/GRID/GEN cables through the corresponding openings in the enclosure and tighten them to the respective connectors with a 5 mm internal hexagon wrench. Then, secure the connection box to the enclosure with M5 × 16 screws by a 10 mm internal hexagon wrench.

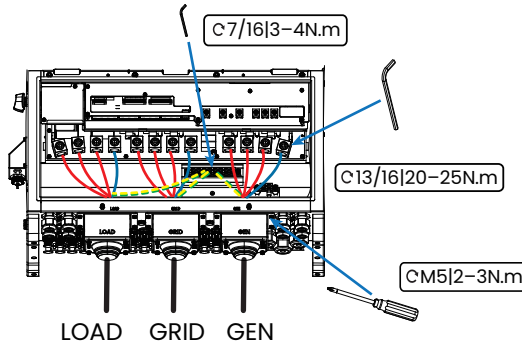

#### Step 4: Battery Side Connection

After the battery power cable is stripped, thread the battery power cable and the battery communication cable through the corresponding cable connector. Then, lock the battery power cable to the corresponding connector with a 5 mm internal hexagon wrench and plug the battery communication cable into the corresponding communication interface.

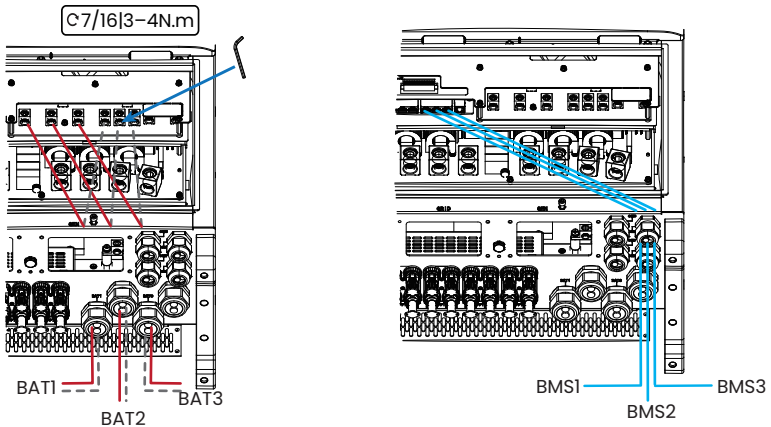
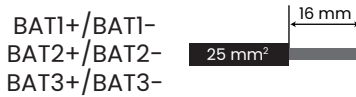

## Method 1: Parallel Mode

Multiple battery modules (BAT1, BAT2, BAT3) are connected in parallel for power, while only one BMS communication line (BMS1) from the master battery is connected to the inverter.

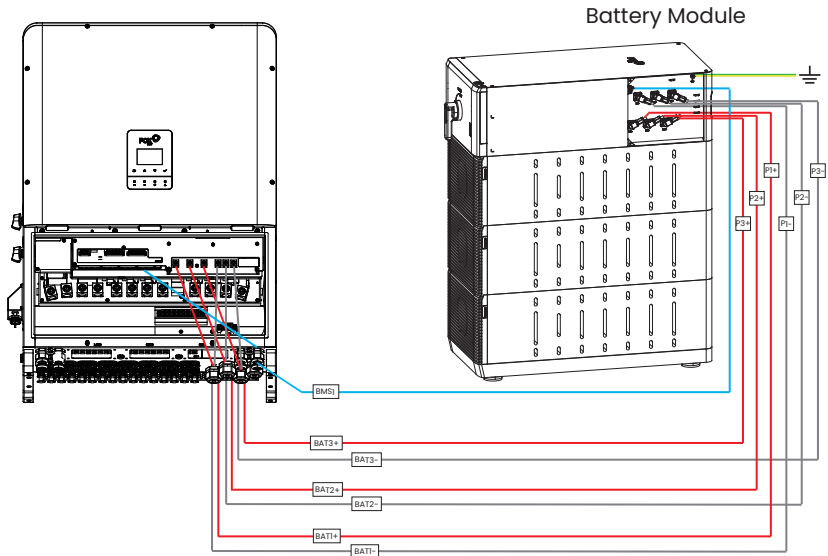

---

### NOTICE

Ensure that one battery is designated as the master BMS. Other batteries must follow its configuration and must not connect their BMS ports to the inverter directly.

---

## Method 2: Independent Mode

Each battery module (BAT1, BAT2, BAT3) is independently connected to the inverter via power cables and dedicated BMS communication lines. All BMS lines (BMS1–BMS3) are directly connected to the inverter to allow individual monitoring and control.

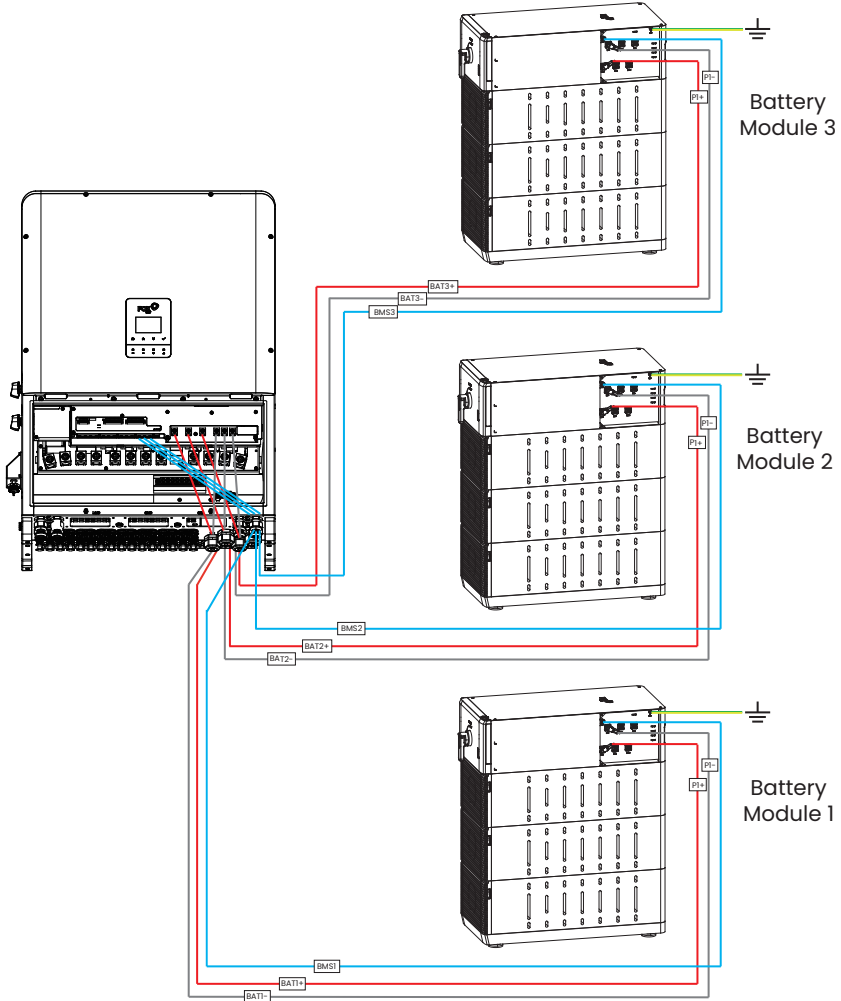

### NOTICE

The inverter can be connected to 1, 2, or 3 battery modules. The diagram above illustrates the wiring example for connecting 3 battery modules.



## Step 6: Antenna Connection

Remove the antenna sealing cap, and screw the antenna into the WiFi antenna port on the inverter.

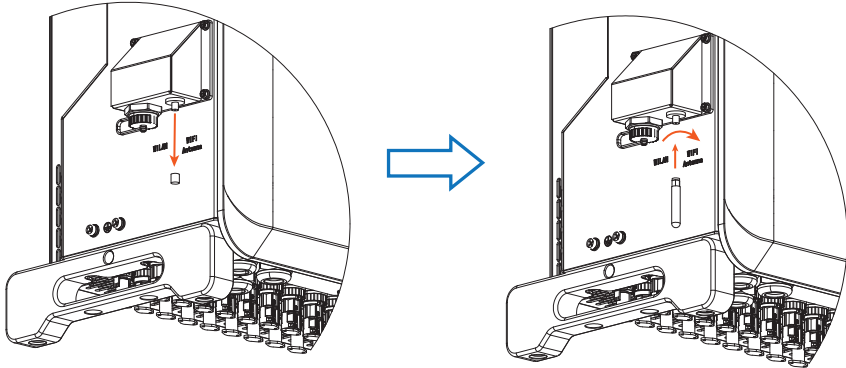

### NOTICE

To ensure stable antenna operation, the antenna locking nut must be securely tightened.

## 5 Startup Procedure

Please follow the steps below to start up the inverter:

1. Ensure the inverter is securely mounted.
2. Confirm that all wiring has been properly completed.
3. Ensure the meter is correctly connected.
4. Ensure the batteries are properly connected.
5. Ensure the load breaker is connected properly (if applicable).
6. Ensure the batteries' Power buttons and switches are turned off.
7. Turn on the PV switch, AC grid breaker, load breaker, and battery breaker. Then, press and hold the batteries' Power buttons for 3 seconds, and release them.

Scan the QR code below to download and install FoxCloud App 2.0. Refer to the guidance to configure the internet.

